

BGE-27PH35-RC10 H/F

Φ6, PIN Type

OMNI-DIRECTIONAL

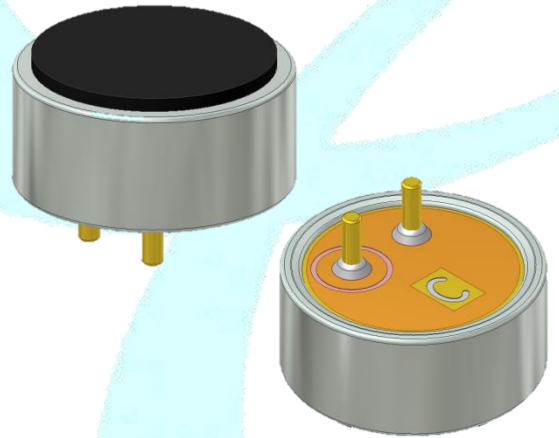

Best sound electronics

Value no1. Micro sound provider

Creative technology starts from respecting of life
of the individuals

Creative technologies to respect human life

Best sound electronics

Value no1. Micro sound provider

We offer you happiness with our excellent technology
beyond an ordinary sound what you expect

Superior technology to deliver happiness

Best sound electronics

Value no1. Micro sound provider

Keep basic fundamentals to fill sound with
new innovations

Creative technologies to respect human life



1. INTRODUCTION

- Analog Electret Condenser Microphone
- Circle Type, PIN type
- Single & Differential Mode
- Sensitivity is Typical -35dBV/Pa
- Omni-directional
- RF Shielded
- Compatible with Sn/Pb and Halogen-free solder process
- RoHS compliant

2. APPLICATIONS

- Smartphones
- Ear-sets, Bluetooth Headsets
- Tablet Computers
- Wearable Devices
- Electrical Appliances
- Voice Recognition Systems of Appliances

3. MODEL NO.

BGE-27PH35-RC10 H/F

4. GENERAL MICROPHONE SPECIFICATIONS

Test Condition : 23 ± 2°C, Room Humidity = 55 ± 20 %, VCC=2.0V, unless otherwise noticed.

Parameter	Conditions	Min	Typ	Max	Units
Directivity		Omni-directional			
Operating Voltage		1.5	-	10	V
Sensitivity Change across Voltage	ΔS-VS, VCC=2.0V to 1.5V	-	-	-3	dB

5. ELECTRO-ACOUSTIC CHARACTERISTICS

Test Condition : $23 \pm 2^\circ\text{C}$, Room Humidity = $55 \pm 20\%$, $V_{CC}=2.0\text{V}$, unless otherwise noticed.

Parameter	Conditions	Min	Typ	Max	Units
Sensitivity (S)	94dB SPL at 1kHz, $0\text{dB}=1\text{V}/\text{Pa}$	-38	-35	-32	dBV/Pa
Output Impedance (Z_{out})	94dB SPL at 1kHz	-	-	2.2	$k\Omega$
Current Consumption	$V_{CC}=2.0\text{V}$, $R_L = 2.2k\Omega$	-	-	500	μA
Signal to Noise Ratio (SNR)	94dB SPL at 1kHz, A-weighted	67	69	-	dB(A)
Total Harmonic Distortion (THD)	94dB SPL at 1kHz	-	-	0.7	%
	99dB SPL at 1kHz	-	-	1.0	
	107dB SPL at 1kHz	-	-	3.0	
	112dB SPL at 1kHz	-	-	5.0	
Acoustic Overload Point (AOP)	THD>10% at 1kHz	118	-	-	dB SPL

6. MEASUREMENT CIRCUIT

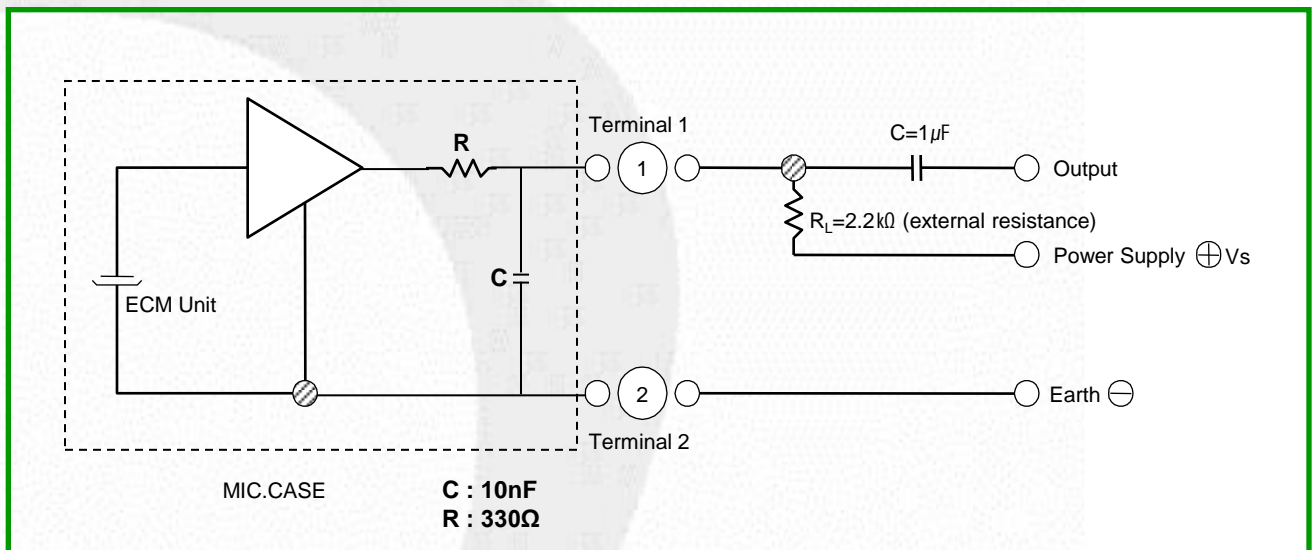

7. TYPICAL FREQUENCY RESPONSE CURVE(FAR FIELD)

Far Field Measurement Condition

Temperature : 23 ± 2 °C

Supply Voltage : 2.0V

Acoustic stimulus : 1Pa (94dB SPL at 1kHz) at 50 cm from the loud-speaker.

The loud-speaker must be calibrated to make a flat frequency response input signal.

Position : The frequency response of microphone unit measured at 50cm from the loud-speaker.

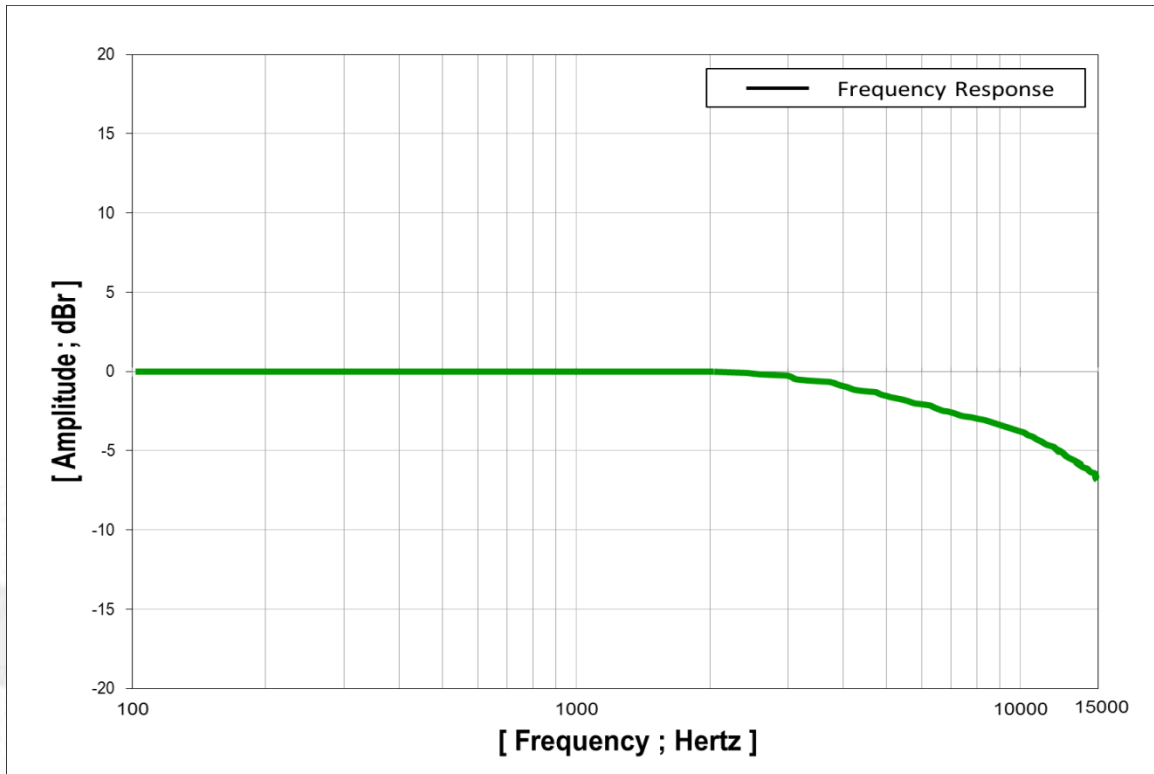

8. MECHANICAL CHARACTERISTICS

※ PCB design & Pin size can be changed by model No.

■ Pin Type

